

Glovebox for critical raw materials



- ergonomic working height
- easy handling of bags via a roller conveyor in front of and inside of the glovebox
- optionally with or without product gate
- both chambers are prepared for an independent filter system or for connection to the central filter
- product storage in a material hopper or in a closed sending bin
- large transparent and foldable windows
- standardized outlet for further material transport
- ejection shaft to the empty bag compressor or to endless film tube
- setting up mobile on rollers/forklift shoes or stationary
- material stainless steel 1.4301 (AISI 304) or according to customer requirement
- also suitable for requirement RL 2014/24/EU (ATEX)

PASSION FOR PERFORMANCE

KITZMANN
GRUPPE



Glovebox for critical raw materials



Product features:

- low contamination feeding of the bags via product gate
- removable grating
- protective gloves antistatic
- internal lighting of the product gate and manual supply chamber
- impingement with e.g. dried air or nitrogen etc. possible

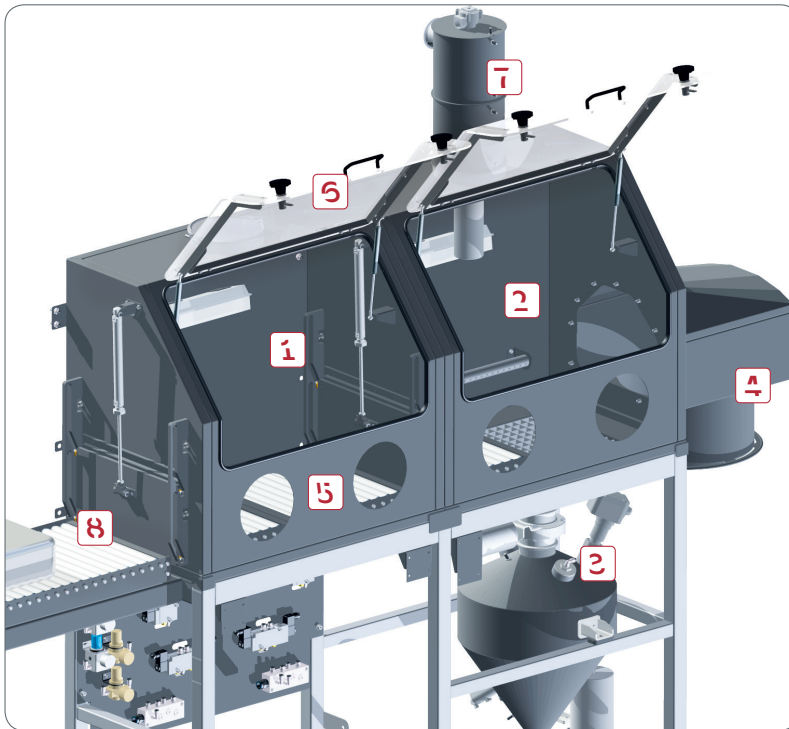

Continuous roller conveyer and window with gas springs

- 1 product gate
- 2 glovebox
- 3 product outlet
- 4 empty sack ejection
- 5 protective gloves
- 6 viewing window
- 7 filtration
- 8 continuous roller conveyer



closed gate chamber



open gate chamber



big windows



sending bin for product conveyance